

VD510-DP

Disposable Material Path
Diaphragm Valve

User Guide



www.fisnar.com

CONTENTS

	Page number
1. Specifications.....	3
2. Unpacking and Inspection.....	4
3. Description.....	4
4. Theory of Operation.....	4
5. Setup Instructions.....	5
6. Typical System Set-Up.....	6
7. Disposable Material Path Removal/Replacement.....	7
8. Maintenance of Air Cylinder O-Ring.....	8
9. Troubleshooting	9
10. Warranty	10
11. Notes.....	11

1. SPECIFICATIONS

	VD510-DP
Size	See below illustration
Weight	0.25 lb. (113g)
Fluid Inlet Port	Luer lock female
Fluid Outlet Port	Luer lock male
Air Inlet Port	10-32 UNF
Auxiliary Air Inlet Port	10-32 UNF
Minimum Air Pressure	70 psi (4.8bar)
Maximum Fluid Pressure	60 psi (4.1bar)
Operating Frequency	Exceeds 400 cycles/min.
Mounting Port	10-32 UNF
Wetted Parts	Black Polyethylene Compound. Black Nylon (Elbow).

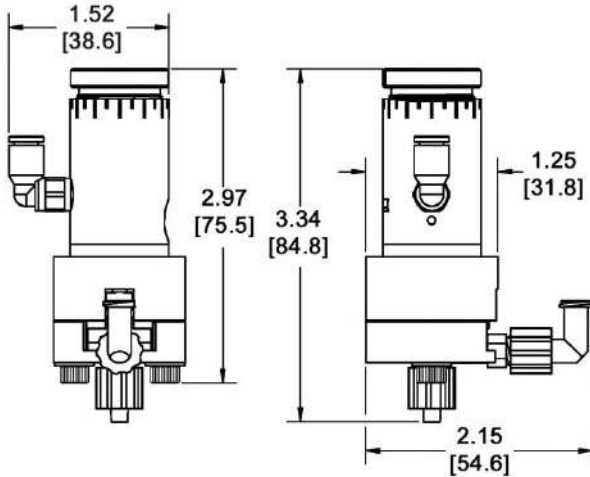

Dimensions are in inches [mm]

Figure 1.0

2. UNPACKING AND INSPECTION

Carefully unpack the valve and examine the items contained in the carton. These will include:

- Valve assembly.
- Mounting bracket and mounting screw.
- 1 x Disposable Material Path.
- 2 x Hex keys (1/8" & 9/64").
- Sample tip kit.
- Fluid line and air hose.
- User guide.

3. DESCRIPTION

The VD510-DP Diaphragm Valve is designed to dispense low to medium viscosity fluids. An internal spring return makes the valve fully adaptable for use with any time/pressure controller. A short opening stroke provides extremely fast, positive shut-off. An external stroke control adjustment makes it easy to fine tune shot sizes. The VD510-DP Diaphragm Valves compact design allows for mounting flexibility and easy integration into automated applications.

4. THEORY OF OPERATION (Refer to figure 2.0)

The VD510-DP Diaphragm Valve is normally closed, adjustable stroke valve. Input air pressure of **70-90 psi (4.8 to 6.2bar)** through air inlet port (1) drives the piston assembly (2) back, opening the material path, allowing fluid flow from the material inlet (3) to the material outlet (4). Relieving the input air pressure allows the piston return spring (5) to close the diaphragm (6), ensuring rapid "fail-safe" shut-off of fluid flow.

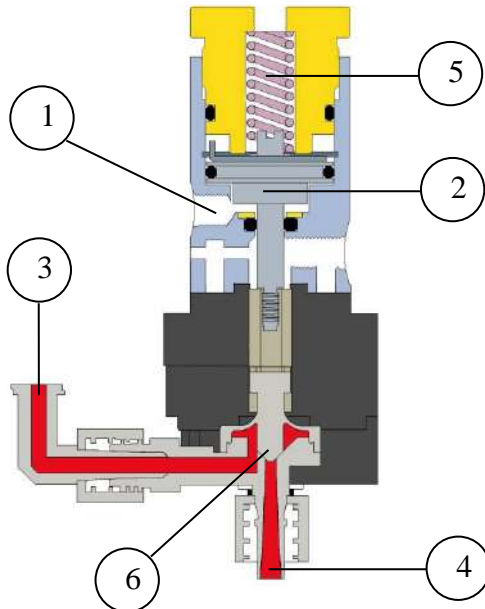

Figure 2.0

5. SETUP INSTRUCTIONS

Refer to Figure 3.0

Note: This installation uses Luer lock adapters shipped with the valve.

1. Connect the fluid feed tube or syringe to the fluid inlet port (1).
Note: Fisnar pressure tanks have a standard 1/4" OD feed tube. If one of these pressure tank is used, a luer lock to 1/4" tube compression adapter will be needed. Please contact Fisnar for more info.
2. Connect the valve airline to the DC200 controller or other pneumatic device that is used to control the valve.
3. Connect the opposite end of the airline to valve air inlet (2).
4. Connect appropriate dispensing tip or nozzle to the fluid outlet port (3).
5. Set the valve controller pressure at **70 psi (4.8bar)**.
6. Set the fluid pressure. **Do not exceed 60 psi (4.1bar)**.
7. Make sure all connections are tight.
8. Place container under the outlet and activate the valve until the fluid flows steady.

The amount of fluid that flows through the valve is determined by:

- Valve open time
- Fluid reservoir pressure
- Dispensing tip size
- Stroke adjustment knob position

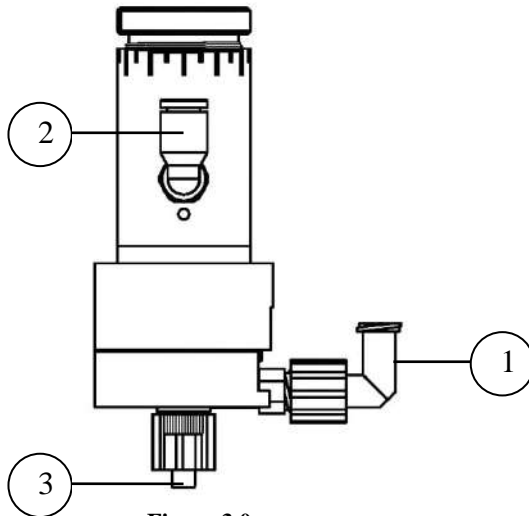
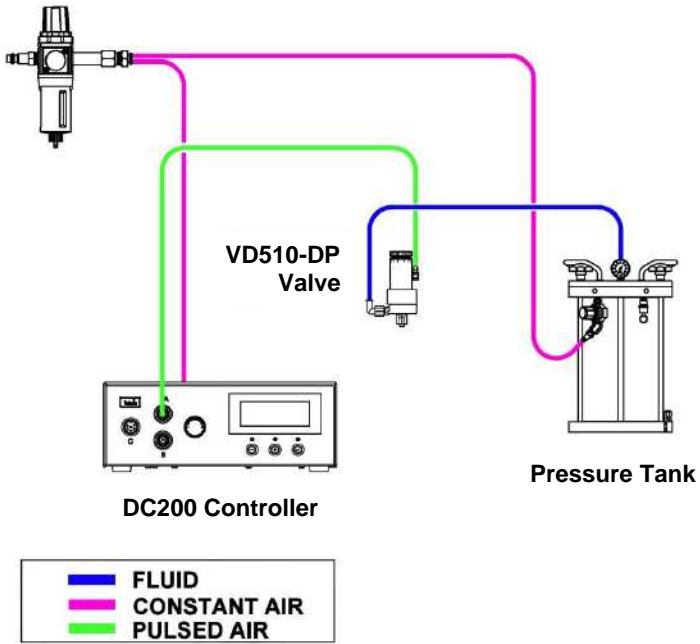

Figure 3.0

6. TYPICAL SYSTEM SET-UP



Note: Fisnar pressure tanks have a standard 1/4" OD feed tube. If one of these pressure tank is used, a luer lock to 1/4" tube compression adapter will be needed. Please contact Fisnar for more info.

Optional Syringe Feeding

1. Attach optional syringe bracket as shown below.
2. Use insert rings for syringe sizes 3cc – 10cc.
3. Ensure syringe is under constant air pressure.

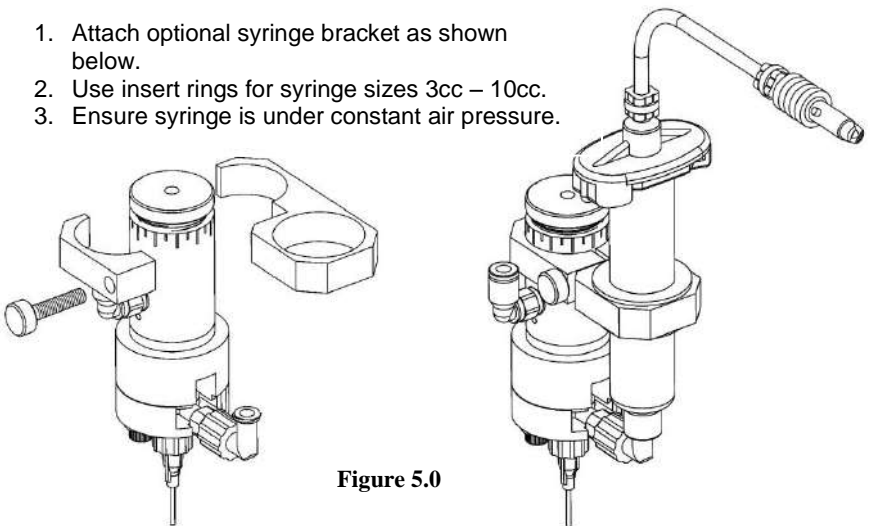

Figure 5.0

7. DISPOSABLE MATERIAL PATH REMOVAL/REPLACEMENT:

Removal of a feed path assembly: Refer to figure 6.0

1. Release fluid pressure.
2. Remove syringe barrel or fluid line from the valve.
3. Loosen the lower receiver screws (4 - 5 turns) and pull out disposable material path.
4. Dispose of the used feed path assembly in an appropriate waste container.

Installation of a new feed path assembly: Refer to figure 6.0

1. Insert a new feed path assembly into the valve housing. Ensure correct fitment into the actuator.
2. Tighten lower receiver screws to torque setting specified below.

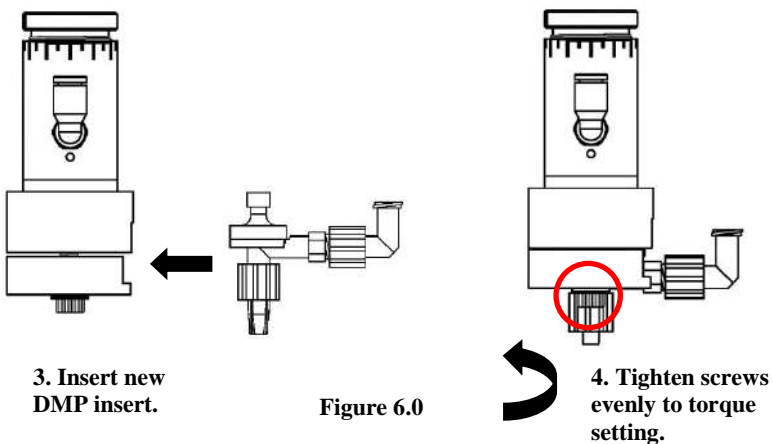
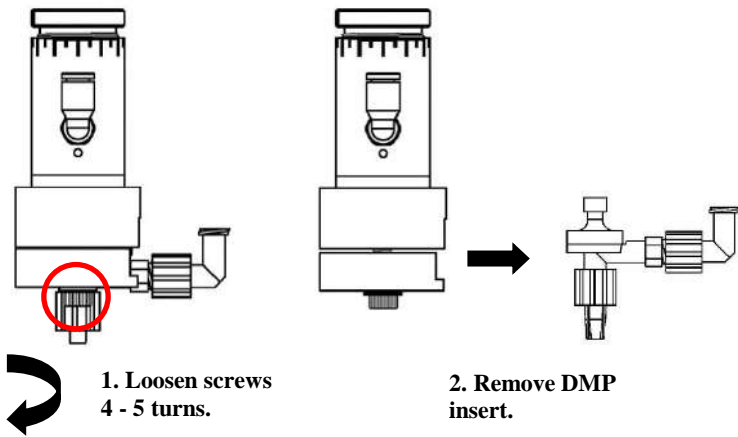

Figure 6.0

Torque Specifications	14 in lb. (1.58 N-m)
-----------------------	----------------------

8. MAINTENANCE OF AIR CYLINDER O-RING (Refer to figure 7.0 and 8.0)

1. Unscrew receiver screws (1).
2. Remove the DMP (2).
3. Remove the stroke control knob (3) and spring (4).
4. Remove the receiver assembly (5).
5. Remover actuator (6).
6. Remove retaining ring (7), anti-rotate washer (8) and Mylar washer (9).
7. Remove piston (10) from air cylinder (11).
8. Replace O-ring (12) if damaged; otherwise lubricate O-ring with Bimba HT-99, or equivalent.
9. Reinstall piston (10), retaining ring (7), anti-rotate washer (8) and Mylar washer (9).
10. Reinstall actuator (6) as per position in Step 4. 90° offset to the air inlet.
11. Reinstall receiver assembly (5), leaving receiver screws loose.
12. Reinstall spring (4) and stroke control knob (3).
13. Install DMP (2) and set torque on receiver screws. - 14 in lb. (1.58 N-m)

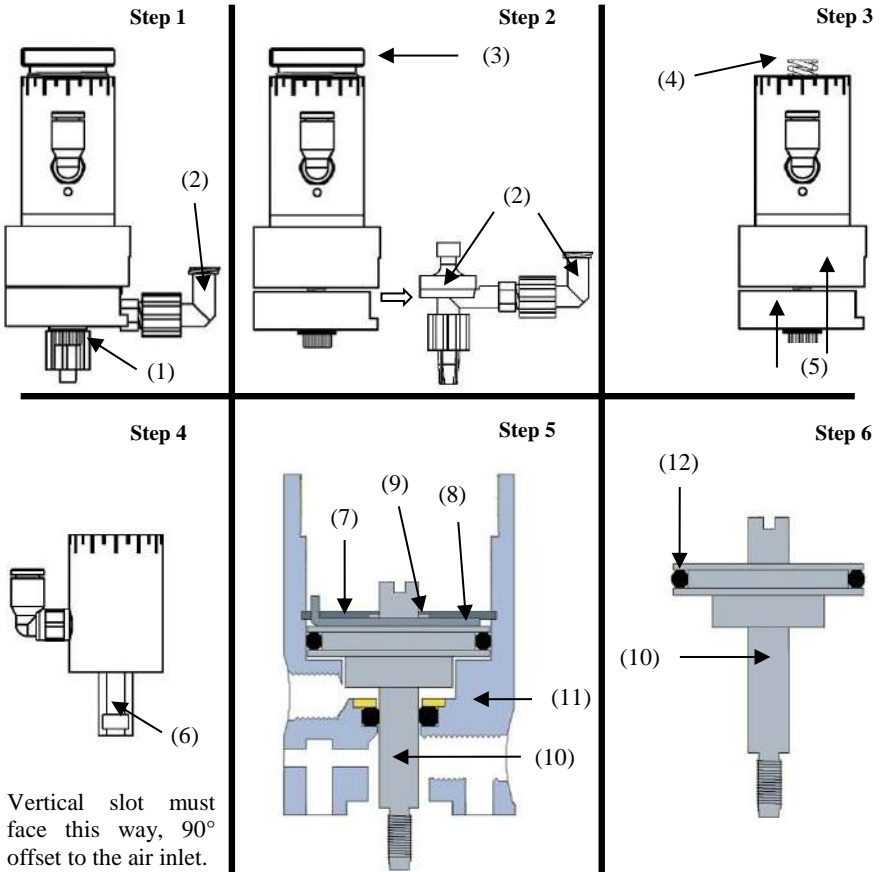

Figure 7.0

9. TROUBLE SHOOTING

PROBLEM	POSSIBLE CAUSE	CORRECTION
No fluid flow	Fluid pressure too low	Increase fluid pressure
	Operating pressure too low	Increase air pressure to 70 psi (4.8bar)
	Dispense tip clogged	Replace tip
	Fluid cured in valve chamber	Replace material path
	Stroke adjustment closed	Open stroke adjustment counterclockwise
Inconsistent fluid flow	Fluid pressure fluctuating	Ensure fluid pressure is constant
	Valve operating pressure is too low	Increase valve pressure to 70 psi (4.8bar)
	Valve open time is not consistent	Check to make sure the valve controller is providing a consistent output
	Air trapped in fluid housing	Purge valve
Fluid drools after the valve closes, eventually stopping	Air trapped in fluid chamber	Purge valve
Steady drip	Worn material path	Replace material path
	Fluid pressure exceeds 60 psi (4.1bar)	Lower fluid pressure

10. LIMITED WARRANTY

Manufacturer warrants this product to the original purchaser for a period of one (1) year from date of purchase to be free from defects in material and workmanship, but not against damages by misuse, negligence, accident, faulty installations and instructions. Manufacturer will repair or replace (at factory's option), free of charge, any component of the equipment thus found to be defective, on return of the component, "PREPAID" to the factory during the warranty period. In no event shall any liability or obligation of the Manufacturer arising from this warranty exceed the purchase price of the equipment. This warranty is only valid if the defective product is returned as a complete assembly without physical damage. The Manufacturer's liability, as stated herein, cannot be altered or enlarged except by a written statement signed by an officer of the company. In no event shall the Manufacturer be liable for consequential or incidental damages. A return authorization is required from Fisnar Inc. prior to shipping a defective unit to the factory.

Manufacturer reserves the right to make engineering product modifications without notice.

All returns must be issued with a Returns Authorization number, prior to return.
Send warranty returns to:

NOTES

