

**SV1000SS
SPRAY VALVE**

OPERATING MANUAL



15 Corporate Drive, Suite E - Wayne - NJ 07470
Tel: (201) 796-1477 E-mail: info@fisnar.com
www.fisnar.com

GENERAL DESCRIPTION

The SV1000SS spray valve is operated by air pressure, providing precise deposit control for low to medium viscosity fluids. SV1000SS is designed for use with valve controller and reservoir tank. The model SVC100 is a suitable valve controller for the SV1000SS spray valve.

The operating air pressure opens the valve, allowing the material to flow. A separate airline creates pressure into the air cap, atomizing the material. Dispensing spray output may be fine-tuned by turning the adjustment knob at the top of the valve. Material deposit and flow rate are controlled by the fluid pressure, needle stroke, distance from the valve to the work surface and the duration that the valve is opened.

SPECIFICATIONS

Weight	:	10.25oz (290 gm)
Operating air pressure	:	70 to 100 psi (5 to 7 bar)
Atomizing air pressure	:	1 to 30 psi (0.1 to 2 bar)
Fluid pressure	:	1 to 100 psi (0.1 to 7 bar) – Depends on the viscosity of the material being sprayed
Material viscosity	:	Up to 1000cps
Nozzle diameter	:	0.028” (0.71 mm)
Flow rate	:	Up to 28cc/sec
Operating frequency	:	Over 200 cycles/min
Spray angle	:	12°
Spray pattern	:	Circular (conical spray)
Operating air inlet	:	10-32 thread with push-in fitting for 1/4 tube
Atomizing air inlet	:	10-32 thread with push-in fitting for 1/4 tube
Material inlet	:	1/8 NPT with compression fitting for 1/4 tube
Mounting hole	:	1/4 – 20 UNC

OPERATING INSTRUCTIONS

Applying a minimum of 70 psi (5 bar) air pressure to the air inlet will open the valve. The operating air pressure will force the piston to pull back the needle from the valve seat, allowing the material to flow. Material is supplied to the material inlet through a 1/8 NPT port. The atomizing air supplied through a 10-32 port creates pressure into the air cap, atomizing the dispensing material.

When the operating air pressure is released, the compression spring will push the needle/piston assembly back onto the valve seat, closing the material flow. A delay in closing the atomizing air is recommended to make sure that dispensing material is fully atomized after the valve closes.

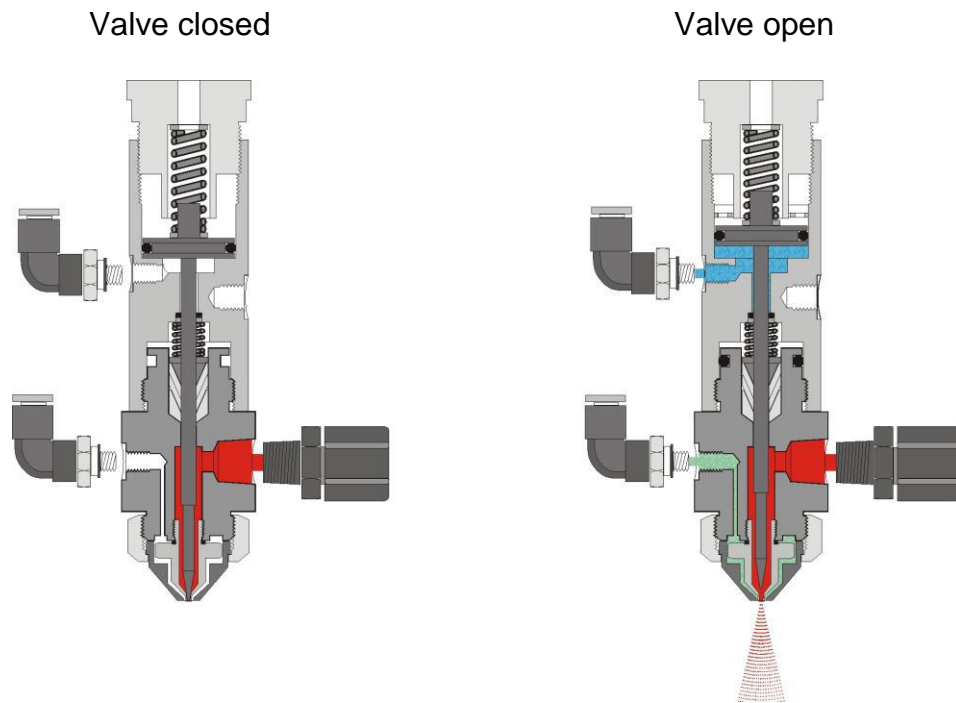

NOTE: Do not apply air pressure or fluid pressure more than the standard specifications.

SETUP

Mount the SV1000SS spray valve using the rod mount (580033) supplied with the valve.

Connect the material feed tubing from the gravity fed bottle, reservoir tank or pressure chamber to the material inlet port of the valve, using the male connector (560715-BLACK). Set the fluid pressure according to the viscosity of the material being sprayed.

Connect the operating air line from the spray valve controller to the operating air inlet of the valve, through the male elbow push-in fitting (561964). Set the operating air pressure to 70 psi (5 bar).

Connect the atomizing air line from the spray valve controller to the atomizing air inlet of the valve, through the male elbow push-in fitting (561964). Set the atomizing air pressure according to the viscosity of the material being sprayed.

Material deposit and flow rate are controlled by the fluid pressure, atomizing air pressure, needle stroke, distance from the valve to the work surface and the duration that the valve is opened.

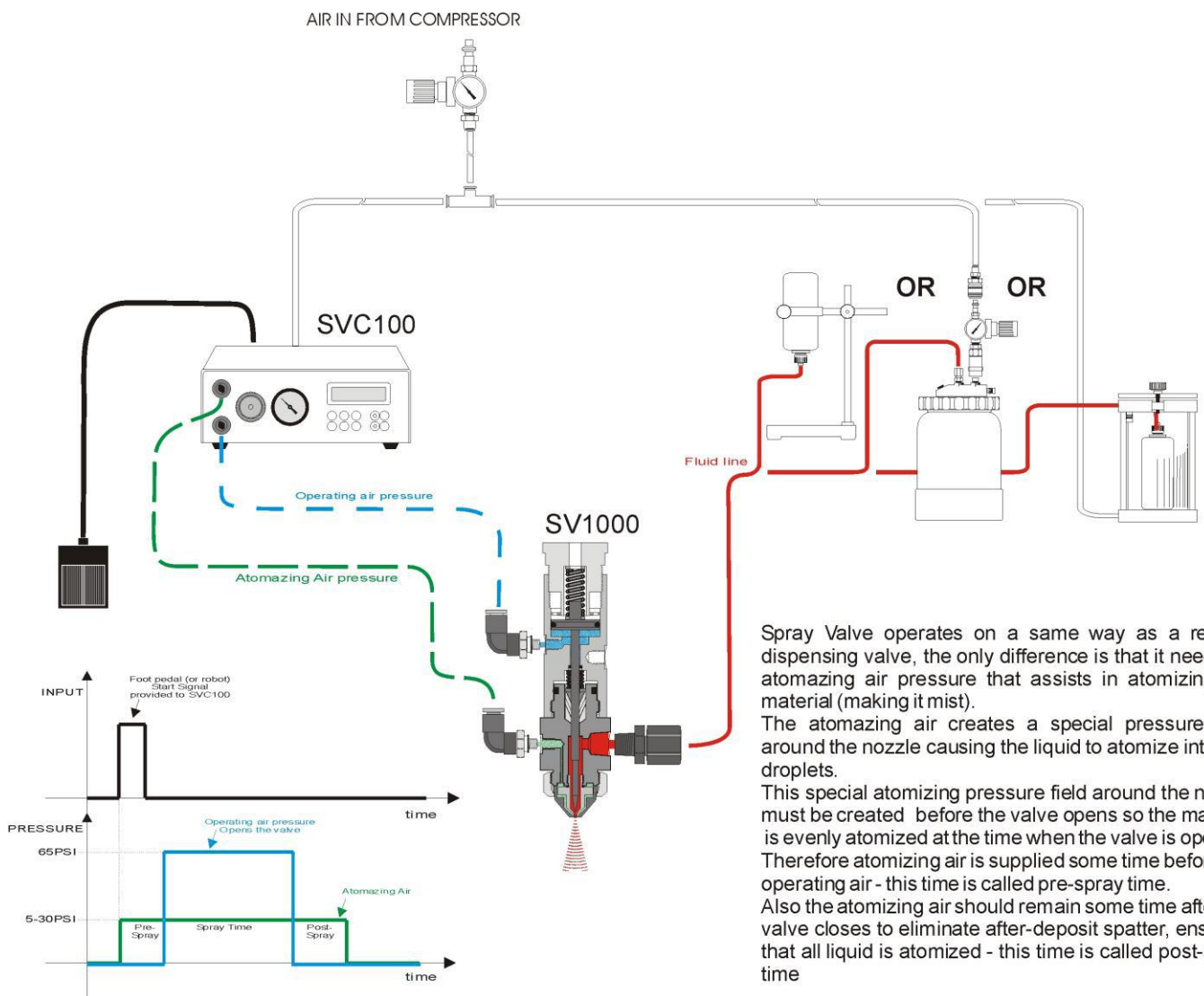

CLEANING

It is recommended to clean the wetted parts of the valve, especially when the valve is used to dispense natural hardening type of materials. Clean the valve by continuously dispensing a liquefied detergent before such material hardens. Carefully select a suitable liquefied detergent depending upon the materials.

When disassembling the material chamber of the valve for cleaning, make sure to clean the air cap, valve seat, needle and the material chamber.

DISASSEMBLING AND ASSEMBLING

Disassembling the material chamber

- (1) Remove all fittings and hoses from the spray valve.
- (2) Completely unscrew the adjustment knob (562106) and remove the nylon washer (562103) and the compression spring (562105).
- (3) Remove the air cap retainer (562090), the air cap (562091), the valve seat (562092) and the O-ring (562093).
- (4) Unscrew the air cylinder (562100) from the material chamber (562094).
- (5) Remove the packing retainer (562096), the packing set (562095) and the O-ring (562111).

As the valve operates, the packing set will wear out and must be replaced.

Assembling the material chamber

- (1) Insert the packing set (562095) and the packing retainer (562096) into the material chamber (562094) and reinstall the O-ring (562111).
- (2) Screw the air cylinder (562100) onto the material chamber (562094). Be careful not to screw in too tightly.
- (3) Reassemble the O-ring (562093), the valve seat (562092), the air cap (562091) and the air cap retainer (562090).
- (4) Reinstall the nylon washer (562103), the compression spring (562105) and the adjustment knob (562106).

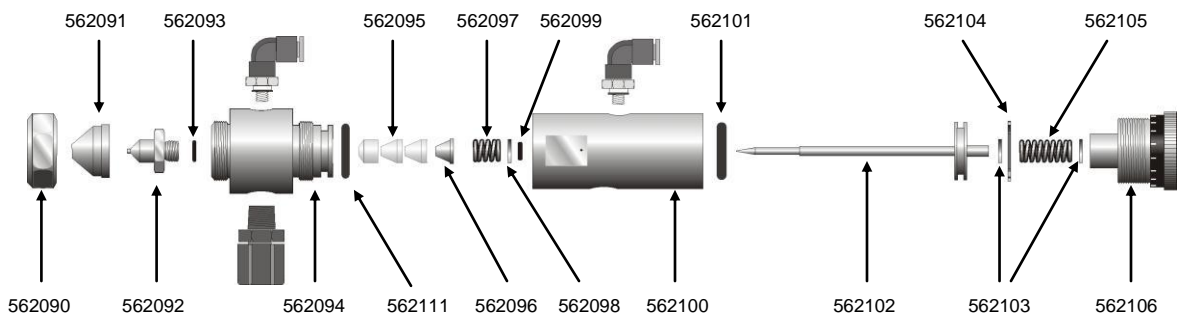

Disassembling the air cylinder

- (1) Remove all fittings and hoses from the spray valve.
- (2) Completely unscrew the adjustment knob (562106) and remove the nylon washer (562103) and the compression spring (562105).
- (3) Unscrew the air cylinder (562100) from the material chamber (562094).
- (4) Remove the retainer ring (562104) using pliers.
- (5) Remove the nylon washer (562103) and the needle/piston assembly (562102).
- (6) Remove the O-ring (562102) from the needle/piston assembly.
- (7) Remove the spring (562097).
- (8) Remove the washer (562098) and the O-ring (562099).

As the valve operates, the O-rings will wear out and must be replaced. Lubricate the O-rings, the air cylinder internal wall and the needle/piston assembly with suitable lubricant.

Assembling the air cylinder

- (1) Insert the O-ring (562099) and the washer (562098) into the air cylinder (562100) and reinstall the spring (562097).
- (2) Reinstall the O-ring (562101) on the needle/piston assembly (562102).
- (3) Insert the needle/piston assembly (562102) into the air cylinder.
- (4) Fit the nylon washer (562103) and reinstall the retainer ring (562104).
- (5) Screw the air cylinder (562100) onto the material chamber (562094). Be careful not to screw in too tightly.
- (6) Reinstall the compression spring (562105), the nylon washer (562103) and the adjustment knob (562106).

TROUBLESHOOTING

No.	PROBLEM	CAUSE	SOLUTION
1	Material is not dispensed.	<ol style="list-style-type: none"> 1. Operating air is not properly connected. 2. Operating air pressure is too low. 3. Valve doesn't open. 4. Material is not fed to valve. 5. Material is hardened inside the valve. 	<ol style="list-style-type: none"> 1. Check air connection, etc. and connect properly. 2. Increase operating air pressure to 70 psi (5 bar). 3. Check if the adjustment knob is excessively screwed. Adjust properly. 4. Increase material pressure. 5. Disassemble and clean valve, or replace parts.
2	Material is not atomized	<ol style="list-style-type: none"> 1. Atomizing air pressure is too low. 2. Material is hardened between the air cap (562091) and the valve seat (562092). 	<ol style="list-style-type: none"> 1. Increase the atomizing air pressure. 2. Disassemble the air cap and clean the air cap and the valve seat.
3	Material doesn't stop.	<ol style="list-style-type: none"> 1. Valve is not turned OFF. Needle/piston assembly (562102) doesn't seat properly in the valve seat (562092). 2. Air cylinder (562100) was reassembled incorrectly onto the material chamber (562094). 3. Compression spring (562105) is damaged. 	<ol style="list-style-type: none"> 1. Clean the needle and the valve seat and replace worn or damaged parts. 2. Reassemble the valve following the assembling instruction. 3. Replace the compression spring.
4	Material is not clearly cut off after valve is turned OFF.	Atomizing air pressure is too low.	Increase the atomizing air pressure.



15 Corporate Drive, Suite E - Wayne - NJ 07470
 Tel: (973) 646-5044 E-mail: info@fisnar.com
 www.fisnar.com

TECHNICAL
 SERVICE
 INFORMATION

SHEET 1 OF 1

REVISION

A OCT 10, 2004

PRODUCT
 DESCRIPTION

SV1000SS SPRAY VALVE

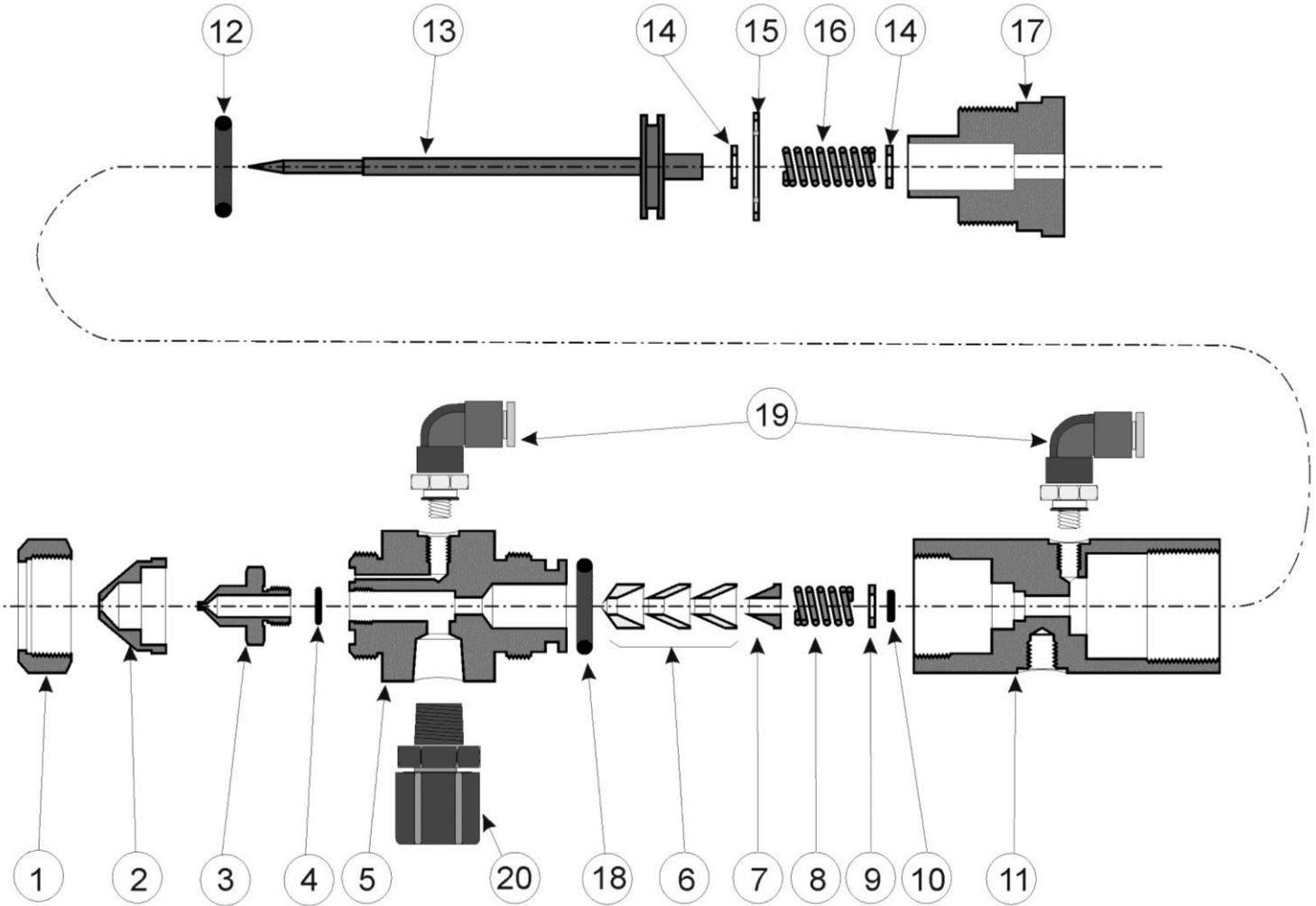

NO.	PART NUMBER	DESCRIPTION	QTY.	NO.	PART NUMBER	DESCRIPTION	QTY.
12	562101	O-RING, VITON (AN016)	1	24*	562112	PACKING REMOVAL TOOL	**
11	562100	AIR CYLINDER, 303SS	1	23*	580033	ROD MOUNT	1
10	562099	O-RING, VITON P3	1	22*	560524	HOSE ASSEMBLY SET, 6 FEET, P.E.	2
9	562098	WASHER, 303SS	1	21*	561415	TUBING, 6 FEET, 1/4" O.D. P.E.	1
8	562097	SPRING, 303SS	1	20	560715-BLACK	BLACK MALE CONN.1/4TUBE-1/8PIPE	1
7	562096	PACKING RETAINER, 303SS	1	19	561964	MALE ELBOW PUSH IN FITTING	2
6	562095	PACKING SET, TEFLON	1	18	562111	O-RING	1
5	562094	MATERIAL CHAMBER, 303SS	1	17	562106	ADJUSTMENT KNOB, 303SS	1
4	562093	O-RING, VITON (P12.5)	1	16	562105	COMPRESSION SPRING, 303SS	1
3	562092	VALVE SEAT, 303SS	1	15	562104	RETAINER RING, 303SS	1
2	562091	AIR CAP, 303SS	1	14	562103	NYLON WASHER	2
1	562090	AIR CAP RETAINER, 303SS	1	13	562102	NEEDLE PISTON ASSEMBLY, 303SS	1

* Not Shown ** Not Included

DRAWN BY: D. KITANSKI

FILE NAME: \SV1000SS