

PDV-1000-LF SERVO VALVE

OPERATING MANUAL



I&J FISNAR INC.

2-07 Banta Place, Fair Lawn, NJ 07410-3002 USA
TEL. (201)796 - 1477 FAX. (201)794 - 7034
info@ijfisnar.com <http://www.ijfisnar.com>

The PDV-1000-LF is a positive displacement servo dispensing valve designed primarily for dispensing solder paste. The valve can be used for other applications such as brazing paste, glass filled epoxy, masking, and chip bonding.

The valve is field maintainable and can easily be taken apart to service or clean. The valve is designed for virtually zero dead space, but if curing does occur, the motor and auger assembly can be removed and cleaned with minimal effort. Also, the feed tube is disposable so there's no need for extensive flushing of the valve body with solvent.

The valve operates using a 24V DC servo motor attached to a reduction gearbox. Every valve has a custom endcap which protects the motor terminals and a plug assembly that allows the valve to be easily disconnected from its power supply for servicing, cleaning, or valve change over. PDV-1000-LF offers many options to choose from such as two gearbox ratios, three screw pitches, and four syringe holder sizes. See chart for a complete listing of valve options.

WIRING

If the valve is being used with the PDC-2000-LF controller, refer to the operating manual for setup. Use the following key to wire the valve to an existing controller.

PDV-1000-LF

Black - 24VG

White - 24V+

CLEANING AND MAINTENANCE

When disconnecting the valve from its power supply, be sure to hold the valve by the endcap when removing the plug.

1. Using a 1.5 mm hex key, remove the 3 motor mounting screws which are accessible through the underside of the fluid body and slowly remove the motor from the fluid body.
2. Discard the used feed tube and use a pipe cleaner or similar instrument to clean the inside of the material inlet and the luer adapter on the fluid body.
3. If desired, the auger and/or flexible coupling can be separated from the motor by using a .035" hex key and loosening the 2 set screws on each side of the flexible coupling. If necessary, discard the O-ring, replace it with a new one, and lubricate it using a small amount of silicone grease.
4. When done cleaning or servicing the valve, reassemble the auger and/or flexible coupling on the motor. To check for the correct positioning of the auger, slowly insert the motor into the fluid body. The end of the auger must be even with the tip of the luer adapter or just inside of the edge. Adjust the auger and/or coupling as needed.
5. When correct positioning is achieved, slowly reinsert the motor assembly into the fluid body and tighten the 3 motor mount screws. Do not over tighten as the motor housing is plastic and the threads can easily be stripped.
6. Replace the feed tube on the material inlet. The tube attaches by means of a press fit so be sure that the fitting is firmly inserted.
7. Reconnect the air and power supply to the valve and resume operation.

REDUCTION GEARBOX SPECIFICATIONS

Max. recommended output torque - dynamic	0.6 Nm (85 oz-in) at 20 rpm
	0.4 Nm (56.7 oz-in) at 150 rpm
- static	1.5 Nm (212 oz-in)
Max. recommended input speed	5000 rpm
Average backlash	1.5° at no-load
	3° at 0.3 Nm
Radial shaft play (typical)	25 µm at 5 mm from mounting face
End play (typical)	100 µm
Max. recommended side load	10 N (2.2 lbs.) at 8 mm from mounting face
Max. recommended axial load	10 N (2.2 lbs.)
Max. axial static force for press-fit	300 N (67.4 lbs.)
Average efficiency	0.7
# of geartrains / direction of rotation	2 / =
Length	32.5 mm
Mass	25 g
Recommended temperature range	- 30 to +65°C (-22 to +150°F)

ENCODER SPECIFICATIONS

Supply voltage	4 to 18Vcc
Supply current (typical)	5 mA
Output signals	Square wave in quadrature
Output voltage - High level	0.95 Vcc
- Low level	< 0.1 Vcc
Output current - High level	0.02 mA
- Low level	-15 mA
Rise time	5 µs
Fall time	0.2 µs
Signal ratio	50 ± 5%
Electrical phase shift between U1 and U2	90 ± 23 deg.
Frequency range	0 to 50 kHz
Operating temperature range (rotor)	-20 to +60°C

□ **PDV-1000-LF STANDARD SPECIFICATIONS**

MOTOR VOLTAGE	24V
MOTOR NO-LOAD SPEED	6400 RPM
AVAILABLE GEARBOX RATIOS	16.2 : 1, 19.4 : 1
MECHANICAL TIME CONSTANT	36 ms
AVAILABLE SCREW PITCHS	8, 16, 32
AUGER MATERIAL	STAINLESS STEEL
MINIMUM MATERIAL VISCOSITY	35,000 CPS
SYRINGE SIZES	3, 5, 10, 30 cc
WEIGHT	9 OZ.
MINIMUM DOT SIZE	0.020 in. (FILLED MATERIALS)

ENCODER SPECIFICATIONS

ENCODER OUTPUT	QUADRATURE
ENCODER VOLTAGE	4 – 18 V
NUMBER OF LINES	40
ENCODER RESOLUTION	0.12 DEG

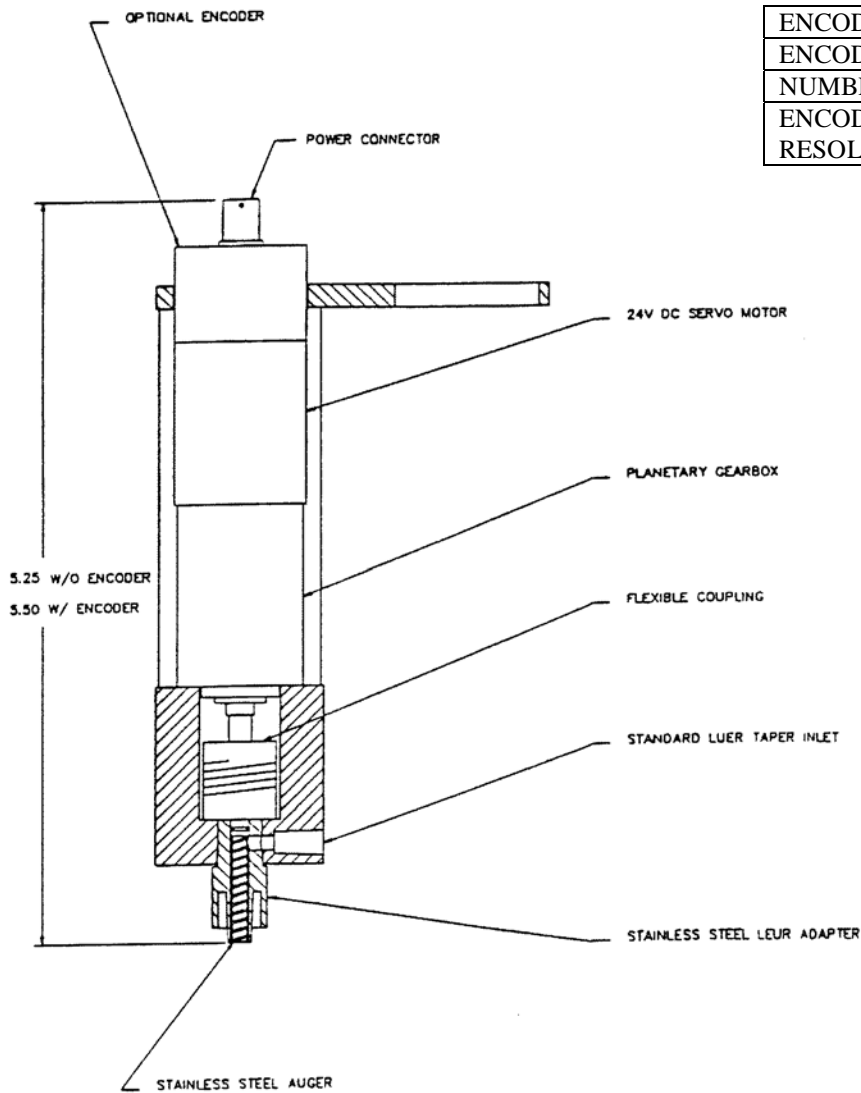

PDV-1000 POSITIVE DISPLACEMENT SCREW TYPE VALVE

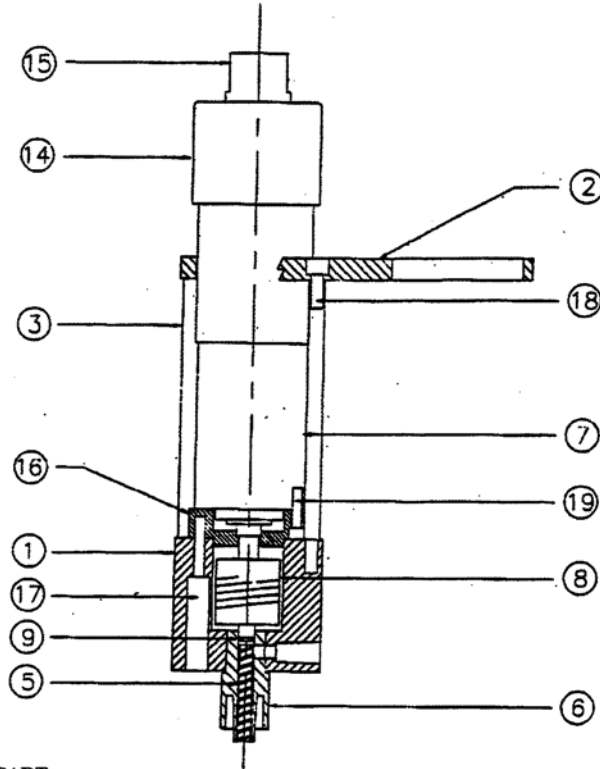

NOTE:

- * RECOMMENDED SPARE PART
- ** PART NOT SHOWN
- # MOTOR W/ENCODER AVAILABLE (P/N 561557E)
- @ MOTOR WITH 19.4 : 2 GEAR BOX RATIO (P/N 561644 / 561644E) AVAILABE

SR. #	PART #	DESCRIPTION	QTY	SR. #	PART #	DESCRIPTION	QTY
1	561648	FLUID BODY	1	11	561639	CAP SCREW (ADAPTER BLOCK)	4
2	561434	10cc SYRINGE BRACKET	1	12	561640	CAP SCREW (MOTOR MOUNT SCREW)	3
3	561645	STAND OFF	4	*13	561446	FEED TUBE	1
**4	561646	ADAPTER BLOCK	1	14	561641	END CAP	1
*5	561437	AUGER 16 PITCH	1	15	561642	ELECTRICAL CONNECTOR (FEMALE)	1
*6	561647	LUER ADAPTER	1	16	561643	MOTOR MOUNT PLATE	1
#7	561557	SERVO MOTOR 16.2 : 1 WITHOUT ENCODER	1	17	561640	CAP SCREW (MOTOR MOUNT SCREW)	3
@	561636	FLEXIBLR COUPLING	1	18	561639	CAP SCREW (ADAPTER BLOCK)	4
*9	561637	O - RING	1	19	561638	CAP SCREW (PLATE MOUNT)	3
10	561638	CAP SCREW (PLATE MOUNT)	3				

TROUBLESHOOTING**PROBLEM****POSSIBLE CAUSE**

Material leaking from tip

- * Feed air too high
- * Worn screw

Material seepage past o-ring

- * Feed air too high
- * Worn O-ring

Servo will not turn

- * Dried material in fluid body
- * Bad electrical connection

Valve does not dispense

- * Feed air too low
- * Dried material in fluid body
- * Clogged feed screw
- * Motor turning in wrong direction
- * Dispensing needle too small

WARRANTY

I&J FISNAR INC. warrants the product for one year from the date of shipment to the original purchaser from I&J FISNAR INC. against defects in material and workmanship on all components but not against damages caused by misuse, negligence, accident, faulty installation, abrasion, corrosion or by "NOT" operating the unit in accordance with factory recommendations and instructions.

I&J FISNAR INC. will repair and/or replace (at I&J FISNAR'S option) free of charge any component of equipment thus found to be defective, upon return of the component "PREPAID" by the customer to I&J FISNAR INC. during the warranty period of the equipment.

Unauthorized repair or modification to the equipment will void the warranty. The use of aftermarket replacement parts, which are not supplied or approved by I&J FISNAR INC., will void any defective warranties and may result in damage to the equipment.

I&J FISNAR INC's written liability, as stated herein, can not be altered or enlarged, except by a written statement signed by an officer of the company. In no event, shall the manufacturer be liable for consequential or incidental damages.

A written authorization is required from I&J FISNAR INC. prior to shipping a defective unit, or sub-assembly to the factory.