

# DSP501A-4 & DSPE501A-4 AUTOMATIC LIQUID DISPENSERS

## OPERATING MANUAL



### Standard Accessories

Qty	Description	Re-order P/N	Re-order Qty/Pkg
1	Power cord – 110V unit	560033	1
1	Power cord – 220V unit	560033E-CE	1
1	Power cord – 220V unit	560033E-PLUG	1
1	Barrel stand	560751	1
1	Air hose	560752	1
1	Foot pedal & cord	560027CW	1
1	30 cc barrel adapter	560004A	1
1	5 cc barrel adapter	560003A	1
3	30 cc barrel	560002E	10
3	5 cc barrel	560001A	10
3	30 cc barrel piston PE	560552	20
3	5 cc barrel piston PE	560550	40
2	Barrel tip cap	580142	10
2	14 gage tapered tip	560783K	25
2	16 gage tapered tip	560010K	25
2	18 gage tapered tip	560011K	25
2	20 gage tapered tip	560012K	25
2	22 gage tapered tip	560013K	25
2	24 gage tapered tip	561338K	25
2	20 gage blunt end tip	560088	25
2	21 gage blunt end tip	560089	25
2	22 gage blunt end tip	560090	25
2	23 gage blunt end tip	560014	25
2	25 gage blunt end tip	560015	25
2	30 gage blunt end tip	560016	25

The DSP501A-4 & DSPE501A-4 are ideal for dispensing applications requiring simultaneous control of between one and four barrels. A common internal manifold distributes the air pressure to four outputs on the side of the unit. A larger internal air solenoid assists in exhausting the greater volume of air found in a multiple barrel configuration. An internal vacuum prevents dripping of very low viscosity liquids.

The DSP501A-4 and DSPE501A-4 provide timer programming from 0.01 to 31 seconds. Foot pedal initiation can be for either maintained or momentary operation.

### Specifications

• <b>Size:</b>	9 ½" x 8 ½" x 2 ⅝" (24 x 21.6 x 6.7cm)
• <b>Weight:</b>	4lbs 2oz (1.9kg)
• <b>Input Voltage:</b>	110V – Model DSP501A-4 220V – Model DSPE501A-4
• <b>Dispense Time:</b>	0.01 - 31 seconds
• <b>Internal Voltage:</b>	24V dc
• <b>Cycle Initiation:</b>	Maintained or Momentary
• <b>Cycle Speed:</b>	600+ /Minute
• <b>Air Input:</b>	80-100psi (5.5-7 bar)
• <b>Air Output:</b>	4 outputs: 1-100psi (0.1-7 bar)
• <b>Standards:</b>	European CE approved unit
• <b>Barrel "Suck-Back" Feature</b>	

### Ordering Guide

Part No	Description
<b>DSP501A-4</b>	Automatic Liquid Dispenser – 110V ac
<b>DSPE501A-4</b>	Automatic Liquid Dispenser – 220V ac

## SETTING UP

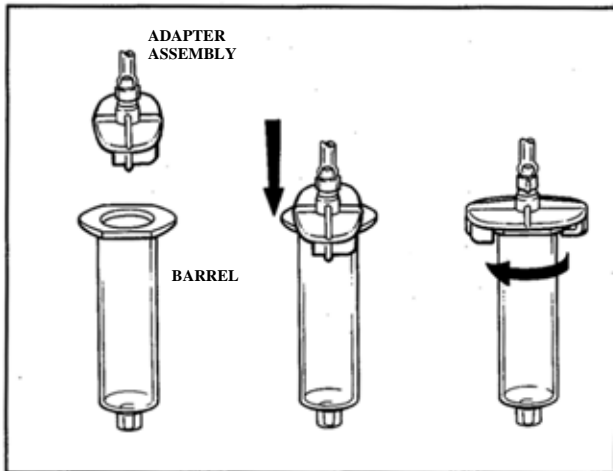

1. Connect air hose to filtered compressed air 70 - 100 psi (5-7 bar) and connect coupling to dispenser.
2. Insert Foot Switch Plug.
3. Insert and twist male quick connect into dispenser. Features simultaneous dispensing from one up to four barrels.
4. Insert power cord female plug into dispenser and insert the male plug into a grounded outlet - CHECK VOLTAGE LABEL on back of unit.
5. Fill barrel (with barrel tip cap on the barrel) with material to be dispensed and lock barrel to adapter assembly as shown.

## AIR & ELECTRICAL SET UP DIAGRAM

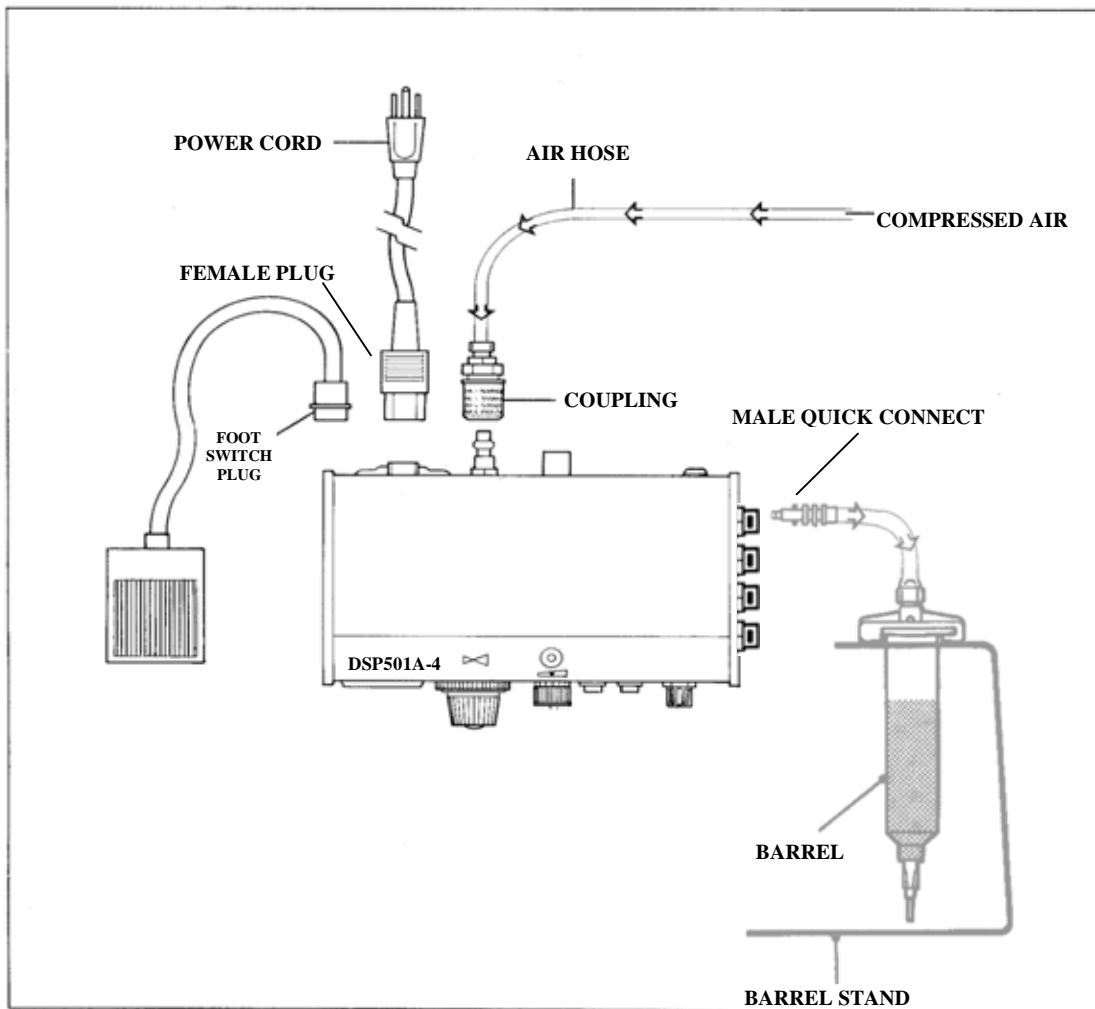

## UNDERSTANDING THE FUNCTIONS OF YOUR DISPENSER DISPLAY

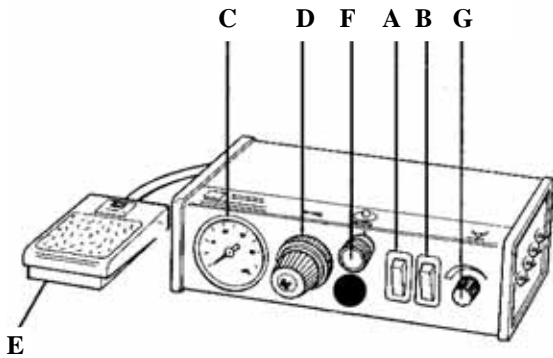

- A** Turn unit on.
- B** Turn amber light on – this will provide continuous flow of material as long as the foot pedal is depressed.
- C** Turning the pressure adjust knob (**D**) allows for adjustments of air pressure.
- E** Push foot pedal to start dispensing.

The amount of liquid dispensed depends on air pressure, size of dispense tip, viscosity of material and time of pulse (**F**).

To produce timed deposits, press (**B**) to turn off amber light.

## HELPFUL HINTS FOR MAKING DEPOSITS

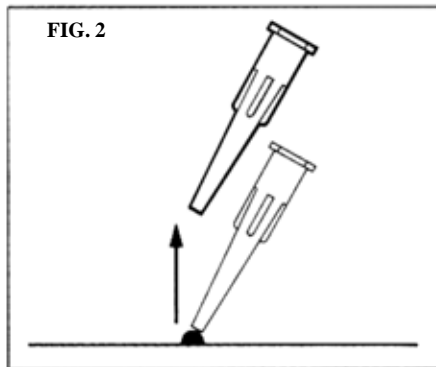
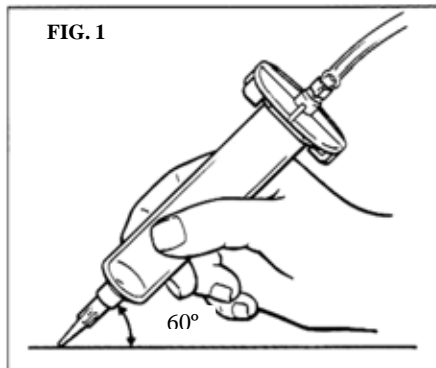

1. Hold the barrel at approximately 60° ( $\pm 20^\circ$ ) angle (Fig. 1).
2. After making deposit remove tip as shown (Fig. 2).
3. Do not permit the liquid to flow back into the controller as shown in Fig. 3.

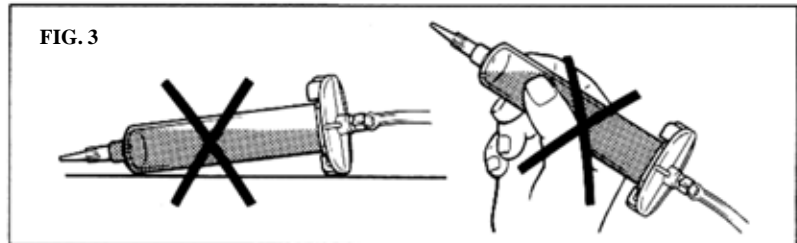

4. Increase or decrease size of dots by either:
  - Increasing or decreasing time only (**F**)
  - Increasing or decreasing pressure only (**C**) (**D**)
  - Increasing or decreasing size of tip
  - Increasing or decreasing any combination of time, pressure and size of tip.
5. To increase pressure, turn knob (**D**) clockwise. To decrease pressure, first turn knob (**D**) counter clockwise past the value desired and then clockwise to the value desired.
6. For thin liquids, like water, you can prevent dripping by slowing turning the vacuum control (**G**) counter clockwise. **WARNING** – Too much vacuum will cause bubbles and suck liquid back into the controller thus creating permanent damage to the unit.

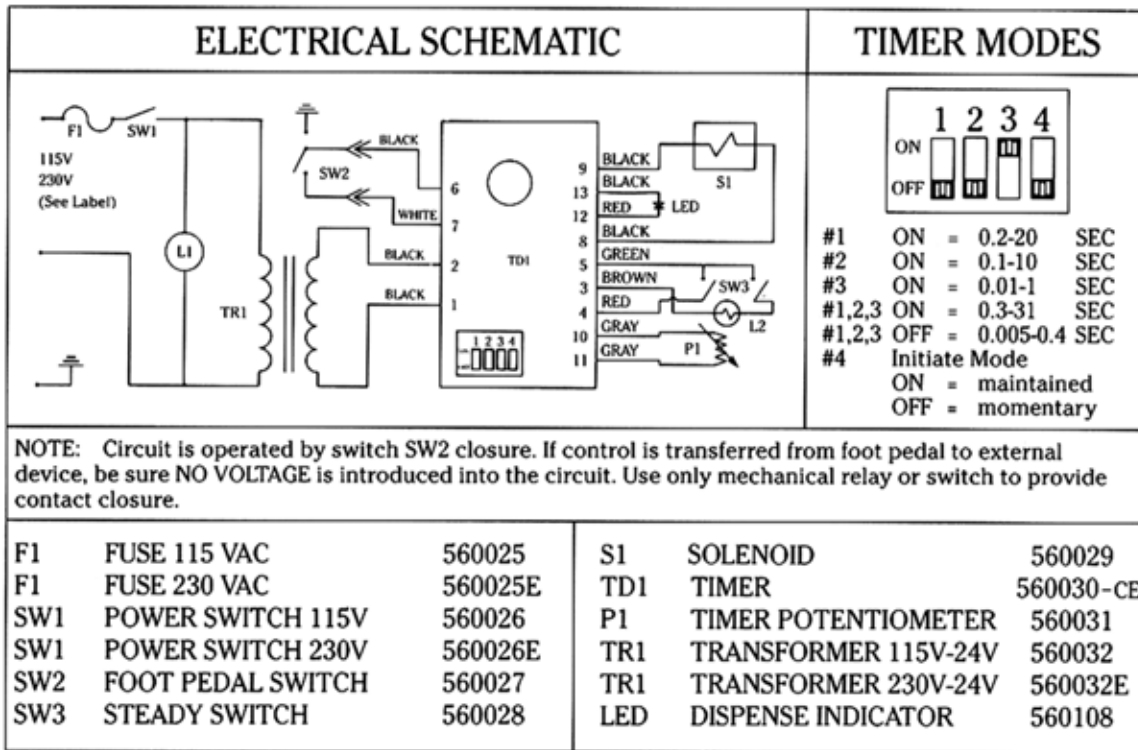

## LIMITED WARRANTY

Manufacturer warrants this product to the original purchaser for a period of two (2) years from the date of purchase to be free from defects in material and workmanship, but not against damages caused by misuse, negligence, accident, faulty installation, abrasion, corrosion or by not operating in accordance with factory recommendations and instructions. Manufacturer will repair or replace (at factory's option), free of charge, any component of the equipment thus found to be defective, upon return of the component to the factory during the warranty period of the equipment. In no event shall any liability or obligation of Manufacturer arising from this warranty exceed the purchase price of the equipment. This warranty is valid only when 5 micron filtered air is used. The manufacturer's written liability, as stated herein, cannot be altered or enlarged except by a written statement signed by an officer of the company. In no event shall manufacturer be liable for consequential or incidental damages. A return authorization is required from I&J FISNAR INC. prior to shipping a defective unit to the factory.

Manufacturer reserves the right to make engineering or product modifications without notice.



**I&J FISNAR INC.**

2-07 Banta Place, Fair Lawn, NJ 07410-3002 USA  
 TEL. (201)796 - 1477 FAX. (201)794 - 7034  
 info@ijfisnar.com http://www.ijfisnar.com

