

# DB815 & DB815-SB FOOT VALVE DISPENSERS



Barrels, tips and barrel adapter assemblies (5 foot) not included



**I&J FISNAR INC.**

2-07 Banta Place, Fair Lawn, NJ 07410-3002 USA  
TEL. (201)796 - 1477 FAX. (201)794 - 7034  
info@ijfisnar.com http://www.ijfisnar.com

# DB815 and DB815-SB

The DB815 & DB815-SB are two basic air-powered controllers. The floor mounted foot operated air control unit includes a built-in pressure regulator, pressure gage and three-way air valve.

The DB815 & DB815-SB are ideal for non-critical dispensing operations. As long as the foot pedal is depressed, fluid will be dispensed.

The units are suitable for all types of fluids. DB815-SB includes a suck-back feature to ensure low viscosity liquids do not drip.

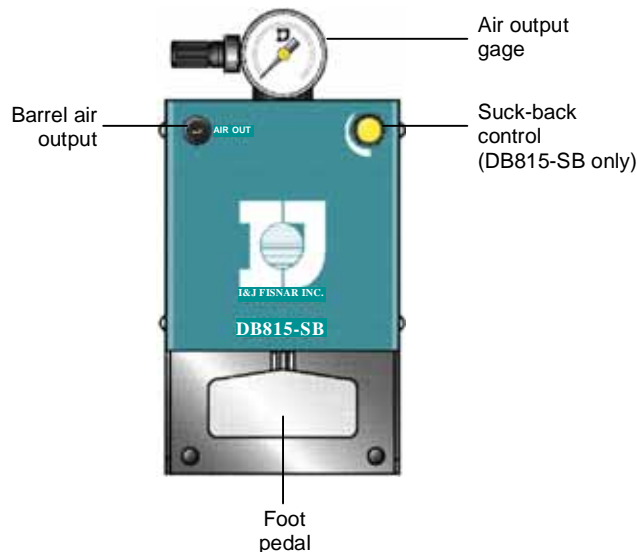

## Specifications

Size:	DB815	4.50" x 8.50 "x 4.88" (11.43 x 21.59 x 12.40cm)
	DB815-SB	4.50" x 8.50" x 5.38" (11.43 x 21.59 x 13.66cm)
Cycle:	Continuously maintained by user	
Foot pedal:	Air valve integral in unit	
Air Input:	70 to 100 psi (5 to 7 bar)	
Air output:	1-100 psi (0.1 – 7 bar)	
Weight:	DB815	3.50 lbs (1.59 kg)
	DB815-SB	3.80 lbs (1.73 kg)



# I&J FISNAR INC.

2-07 Banta Place, Fair Lawn, NJ 07410-3002 USA  
TEL. (201)796 - 1477 FAX. (201)794 - 7034  
info@ijfisnar.com http://www.ijfisnar.com

## TECHNICAL SERVICE INFORMATION

SHEET 1 OF 1

### REVISION

A SEPT 1, 1999

PRODUCT DESCRIPTION

## DB815 FOOT VALVE DISPENSER

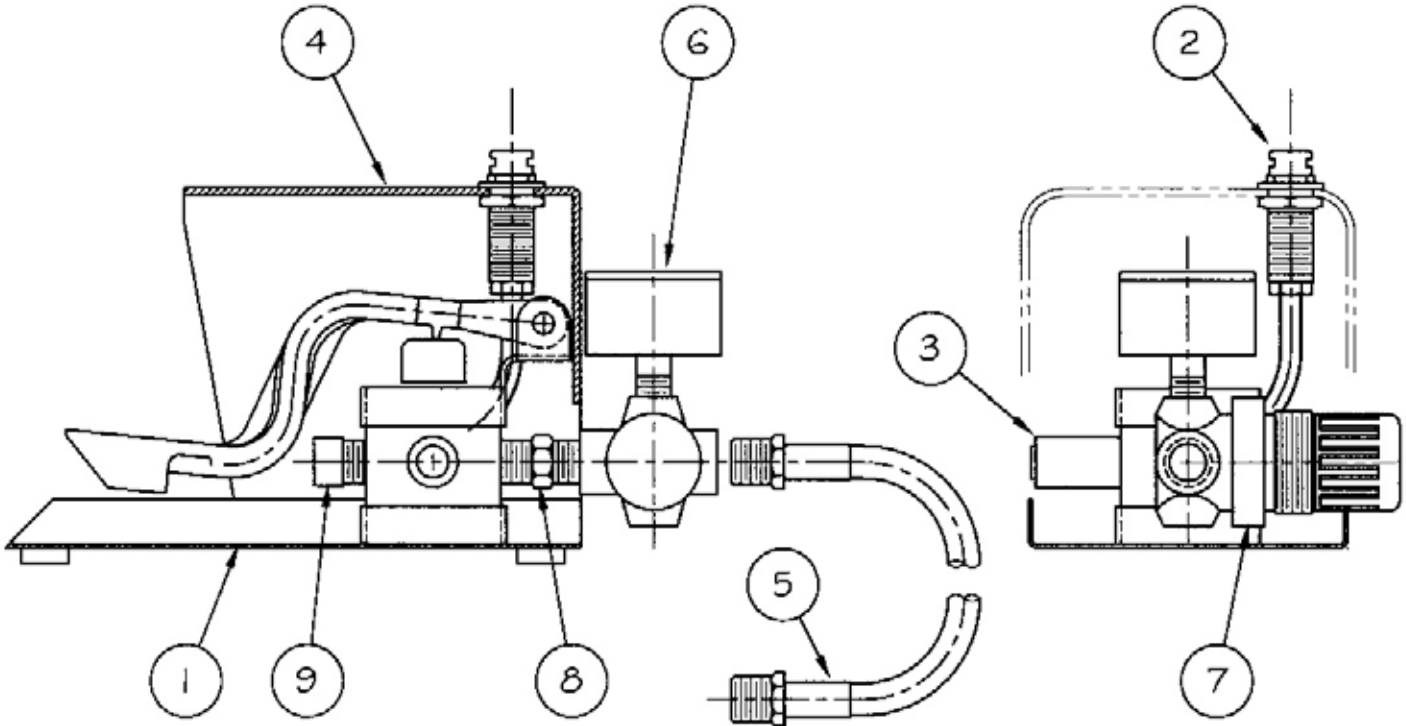

NO.	PART NUMBER	DESCRIPTION	QTY.
9	560713	MALE ELBOW 1/4-NPT BARB	1
8	560716	1/4-NPT NIPPLE	1
7	560779	PRESSURE REGULATOR	1
6	560934	PRESSURE GAGE (1 - 100 PSI)	1
5	561588	AIR HOSE ASSEMBLY	1
4	561605	FOOT VALVE COVER WITH ONE HOLE	1
3	561650	PLASTIC MUFFLER	1
2	2004BA	FEMALE QUICK CONNECT WITH MOUNTING NUT	1
1	DB815-VALVE	VALVE WITH BASE	1

DRAWN BY: G.O. BEUTEL

DATE DRAWN: 4/03/98

FILE NAME: \DB815T.DWG



**I&J FISNAR INC.**

2-07 Banta Place, Fair Lawn, NJ 07410-3002 USA  
 TEL. (201)796 - 1477 FAX. (201)794 - 7034  
 info@ijfisnar.com http://www.ijfisnar.com

TECHNICAL  
 SERVICE  
 INFORMATION

SHEET 1 OF 1

REVISION

A SEPT 1, 1999

PRODUCT DESCRIPTION **DB815-SB FOOT VALVE DISPENSER**

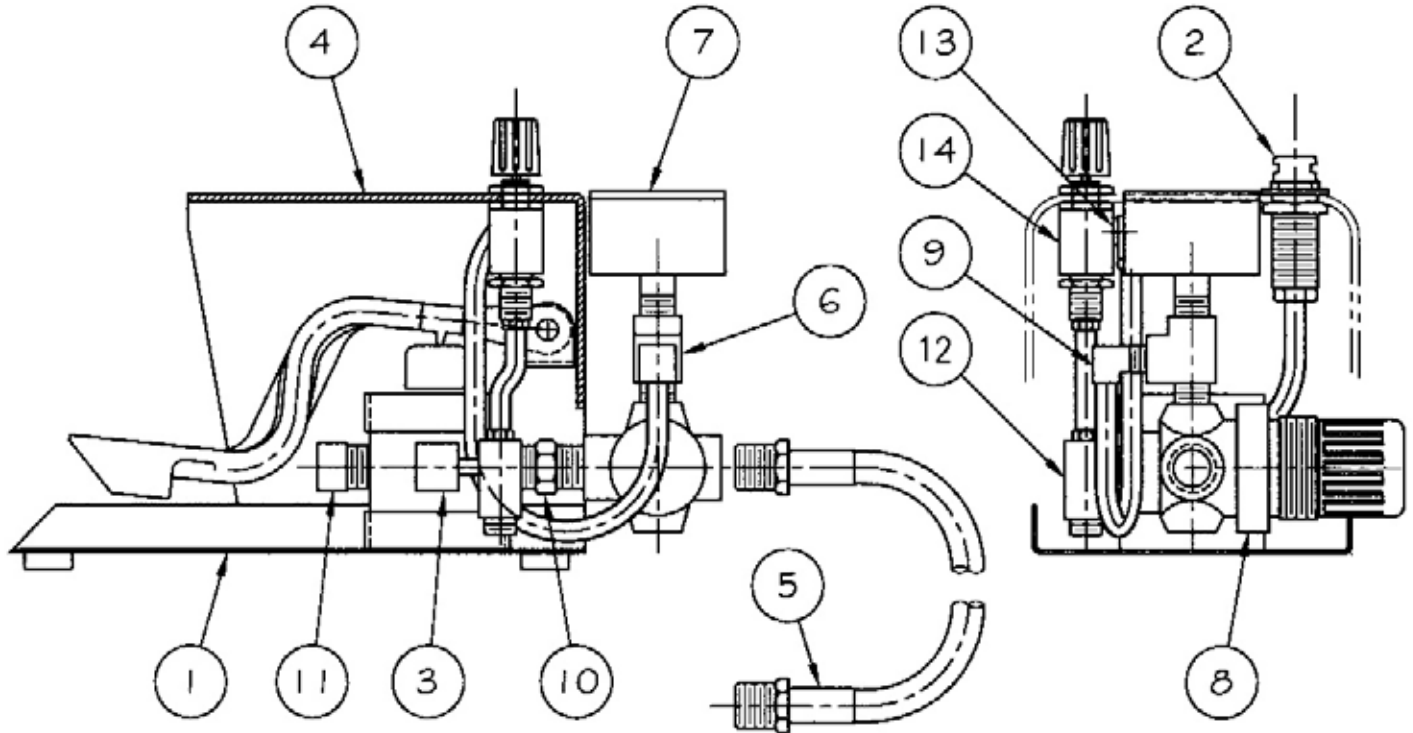

NO.	PART NUMBER	DESCRIPTION	QTY.
14	560686	NEEDLE VALVE	1
13	560687	SWIVEL EL	1
12	560712	VACUUM TRANSDUCER	1
11	560713	MALE ELBOW 1/4-NPT BARB	1
10	560716	1/4-NPT NIPPLE	1
9	560732	MALE ELBOW 1/8-NPT BARB	1
8	560779	PRESSURE REGULATOR	1
7	560934	PRESSURE GAGE (1 - 100 PSI)	1
6	561587	1/8-NPT STREET TEE	1
5	561588	AIR HOSE ASSEMBLY	1
4	561606	FOOT VALVE COVER WITH TWO HOLES	1
3	561649	ELBOW WITH THREAD ON 1/4-NPT BARB	1
2	2004BA	FEMALE QUICK CONNECT WITH MOUNTING NUT	1
1	DB815-VALVE	VALVE WITH BASE	1

DRAWN BY: G.O. BEUTEL

DATE DRAWN: 4/03/98

FILE NAME: \DB815STB.DWG