

# 700PTPCW PINCH TUBE PEN

## *OPERATING MANUAL*

### **GENERAL**

The 700PTPCW Pen is a basic pinch tube type valve. It has several unique features that provide very broad areas of application.

1. The replaceable pinch tube assembly has inlet and outlet fittings molded onto a polyethylene tube. The assembly is capable of shutting off fluid flow with input pressures up to 50 psi of the supply source.
2. The valving or ON/OFF lever actuator provides precision control, capable of making small microdots or continuous beads.
3. A stroke adjustment for the lever is built into the PEN body. This adjustment provides a positive stop point for the lever when dispensing. This adjustment makes possible the dispensing of small dots with a high degree of repeatable control.
4. A wide range of interchangeable fittings can be used to adapt supply hoses from either gravity or pressurized supply reservoirs. The standard supply hose provided with the PEN is a duplicate form of the pinch tube assembly and quickly connects the PEN to almost any supply reservoir, using the appropriate adapter (sold separately).

### **ASSEMBLY**

The 700PTPCW pen is supplied as a pre-assembled applicator. In addition, spare pinch tube assemblies and dispensing needle tips, a supply hose and ¼ NPT adapter are included.

### **PRESSURE SUPPLY**

1. Thread the luer lock adapter (560064) onto your cartridge reservoir with ¼ NPT port. Assemble the reservoir into the appropriate retainer and cap. Twist lock the female end of the supply hose (580047A) onto the adapter and connect the male end onto the inlet side of the 700PTPCW pen.
2. Hold the PEN in your hand as if you were writing. Depress the ON/OFF lever and open the supply reservoir to feed the PEN. As soon as all air has been purged from the supply hose and pinch tube assembly, release the ON/OFF lever to stop flow. Attach the desired needle tip.
3. To fine-tune the flow control or dot size desired, use the included allen wrench to adjust the stroke of the ON/OFF lever. This adjustment is on the underside of the PEN body, opposite the lever.
4. With repeated use, a closely controlled application can be achieved with the availability of adjusting the following:
  - A. Pressure on the supply reservoir
  - B. Needle tip size
  - C. Stroke adjustment on the ON/OFF lever



# I&J FISNAR INC.

2-07 BANTA PLACE-FAIR LAWN-NJ 07410-3002  
 (201) 796-1477 FAX NO. (201) 794-7034  
 E-MAIL info@IJFISNAR.COM  
 INTERNET www.IJFISNAR.COM

## TECHNICAL SERVICE INFORMATION

### PRODUCT DESCRIPTION

## 700PTPCW DISPENSING PEN

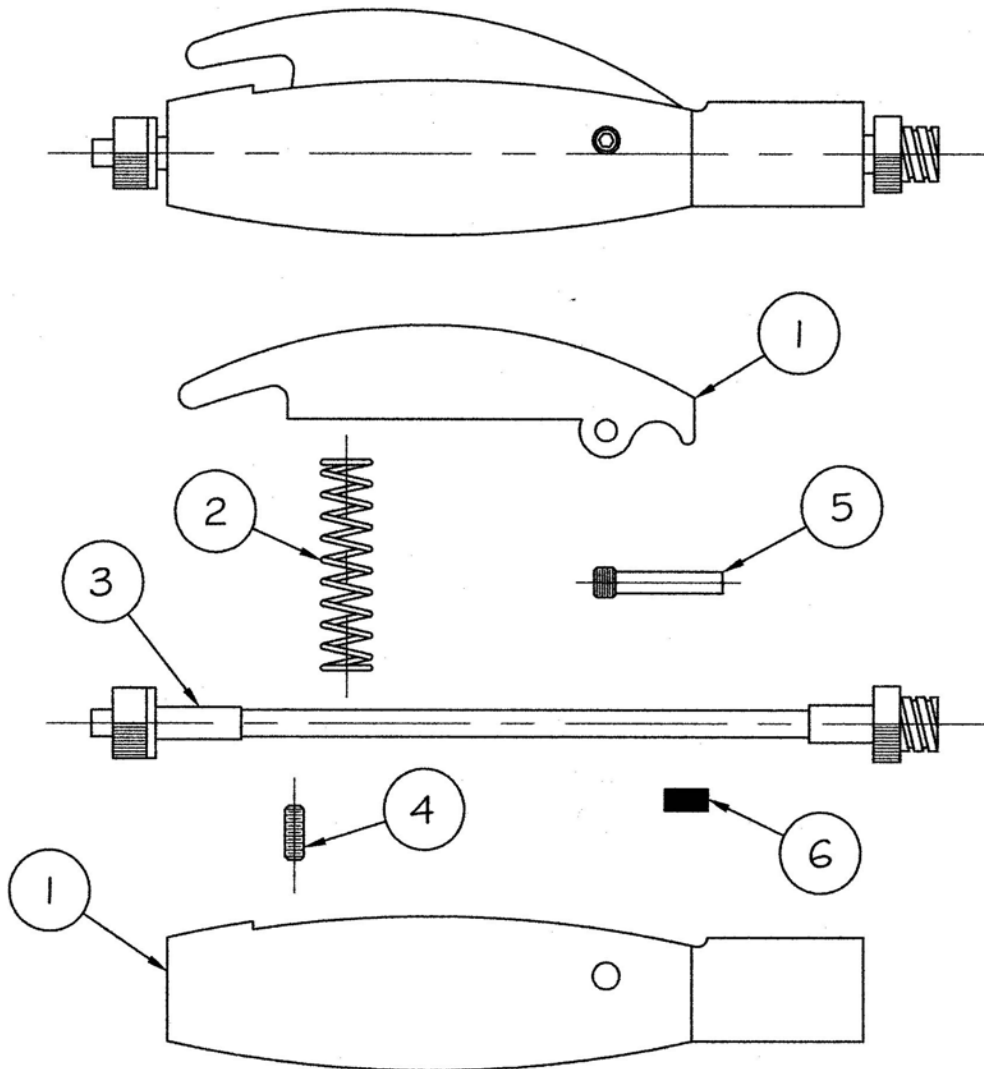

NO.	PART NUMBER	DESCRIPTION	QTY.	NO.	PART NUMBER	DESCRIPTION	QTY.
4	580044	FLOW ADJUST SCREW	1	8	580042A	ALLEN KEY FOR 580042	1
3	580045 A	PINCH TUBE ASSEMBLY	1	7	580044A	ALLEN KEY FOR 580044	1
2	580043 CW	SPRING	1	6	580026NM	PINCH CUSHION	1
1	700PTP-RAW	BODY, HANDLE AND TRIGGER	1	5	580042	PIN (HINGE)	1

## 700PTPCW Pinch Tube Assembly Replacement

1. Unscrew pivot Pin (a), remove Trigger (b) and Spring (c).

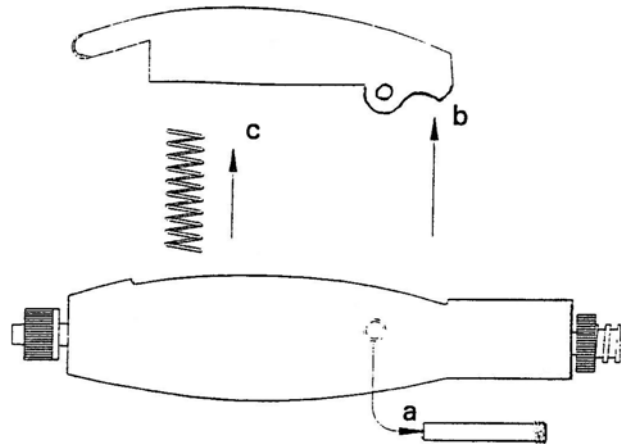

2. Pull one end of Pinch Tube Assembly out (d), stretching it until fitting clears body.



3. Now pull stretched end of Pinch Tube Assembly up (e). Then pull out the opposite end (f) to remove.

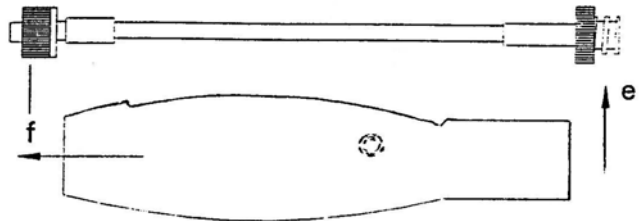

4. To replace new Pinch Tube Assembly, insert fitting of Pinch Tube Assembly in one end of the body (g). Stretch the opposite end over the body until fitting clears (h).

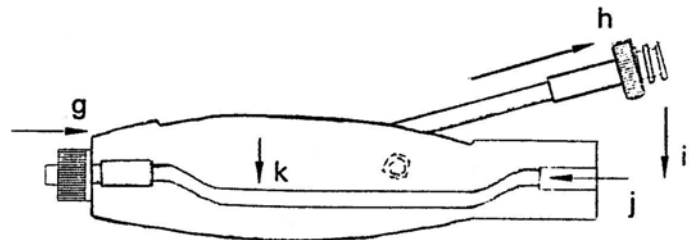

5. Now pull Pinch Tube Assembly down (i) and insert end into the body (j). Finally, secure by pushing Pinch Tube Assembly to the bottom inside of body (k) and re-assemble.



## Parts (\*included)

Qty	Part #	Description
2*	580045A	pinch tube I.D. 0.10"
1*	580042A	3/32" allen key
1*	580044A	1/16" allen key
1*	580047A	polyethylene hose assembly I.D. 0.070" x 24" length
1*	560064	luer lock tip adapter
5*	560017A	teflon lined tips I.D. 0.006" (0.15mm)
5*	560014	blunt end tips 23 gage I.D. 0.013" (0.33mm)
1	580047A-10-18	polyethylene hose assembly I.D. 0.10" x 18" length
1	580047A-10-24	polyethylene hose assembly I.D. 0.10" x 24" length
1	580047A-10-36	polyethylene hose assembly I.D. 0.10" x 36" length



Reservoir ordered separately.

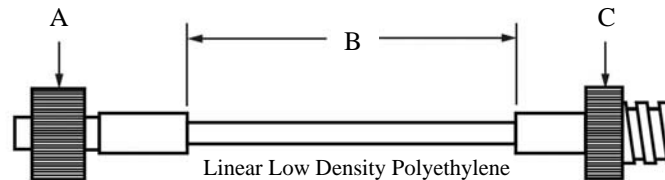

## Pinch tube assemblies (polyethylene)

Part #	A Molded end	B (+/- 0.250") Tube length	C Molded end	Tubing (B)	
				I.D. inch	O.D. inch
580045A	male	3.38"	female	0.100	0.150
580049	male	3.38"	male	0.100	0.150



**I&J FISNAR INC.**

2-07 Banta Place, Fair Lawn, NJ 07410-3002 USA  
 TEL. (201)796 - 1477 FAX. (201)794 - 7034  
 info@ijfnar.com http://www.ijfnar.com